

PROINERT® VALVE ASSEMBLY

DESCRIPTION

The ProInert valve assembly is a self-regulating valve that allows the extinguishing agent to be released from the cylinder at a constant pressure. Because pipe pressure and nozzle flow rates remain constant throughout the discharge, low pressure, small diameter piping can be used throughout the protected space, and the need for installing overpressure relief vents in the room is minimized.

The valve has a forged brass body and is actuated pneumatically. All valves are equipped with a safety disc that will rupture if the pressure within the cylinder exceeds the rating of the safety disc.

OPERATION

Each ProInert valve assembly includes a pressure gauge/low-pressure switch assembly, P/N 02-10672 and a pneumatic valve actuator (P/N IG71-002). The pressure gauge/low-pressure switch provides both visual pressure monitoring at the cylinder as well as continuous remote monitoring at the control panel.

A master or slave actuator is connected to the pneumatic valve actuator. During a system discharge, the master or slave actuator provides nitrogen pressure to the pneumatic valve actuator, causing it to open, which actuates the ProInert valve thus releasing the extinguishing agent. The pneumatic valve actuator has both inlet and outlet ports, allowing up to 60 cylinders to be connected in a series and operated by a single master actuation package.



Fike ProInert Valve Assembly

SPECIFICATIONS

- Part Number: IG71-001-2
- Valve: Material: Brass

APPROVALS

- U.L.
- F.M.
- U.L.C.

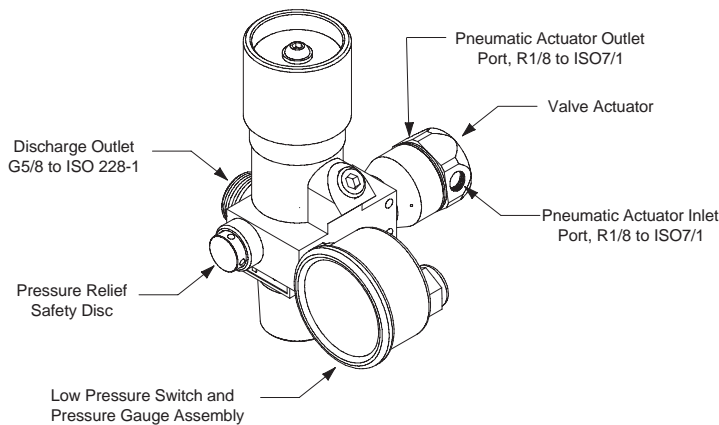

Form No. C.1.47.01