



### PFS

The **PFS** probe is a hermetically sealed reed float switch which signals the presence of liquids. The probe resets immediately after the liquid drops below the activation level.

The unique design of the **PFS** probe integrator eliminates the need for additional power at the probe.

A **PFS** probe is available for the PAL-AT® or LiquidWatch® systems.

The **PFS** can easily be connected into a PAL-AT cable "sensing string" providing increased utilization of the PAL-AT capabilities. Each assembly includes a probe integrator with 60 ft (18 m) of jumper cable to connect to the sensing string, and 20 ft (6 m) of lead cable to attach the float switch to the probe integrator.

The **PFS** probe for LiquidWatch includes the probe adapter that is installed in the 20 ft (6 m) long probe lead wire. Additional lead wire is used if necessary.

#### PAL-AT NOTE:

- A "-S" probe must be connected in the first 5,000 ft (1,500 m) of the sensing string.
- A "-L" probe must be connected more than 5,000 ft (1,500 m) from the PAL-AT panel.

#### PART NUMBERS:

##### PAL-AT:

- PFS-S • 8027623
- PFS-L • 8027910

##### LiquidWatch:

- PFS-LW • 8027902

#### DESCRIPTION:

- Probe Operating Temperature: 0°F to 180°F (-18°C to 80°C)
- Probe Diameter (max): 1.63" (43 mm)
- Probe Lead Length: 20 ft (6 m)
- Activation Level: Water: (S.G.=1.0) 1.0" (25 mm)  
Oil: (S.G.=.75) 1.5" (37 mm)
- Material: Housing: PVC  
Float: Buna-N
- Junction Box: **(PAL-AT ONLY)**  
NEMA 4X 10" x 8" x 4"  
(250 mm x 200 mm x 100 mm)

#### APPLICATIONS:

- SUMPS • MANHOLES

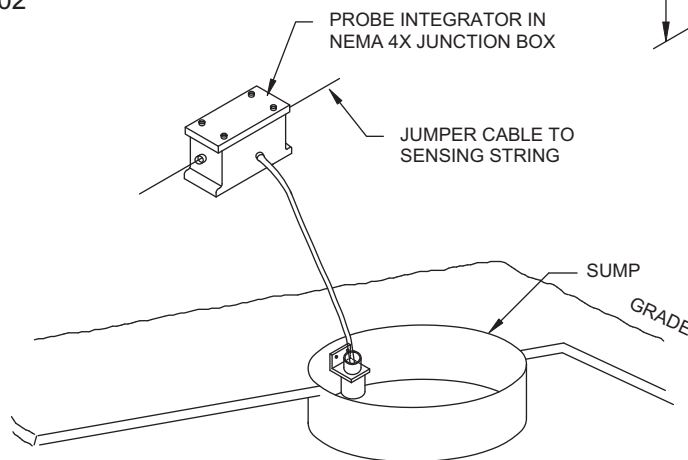
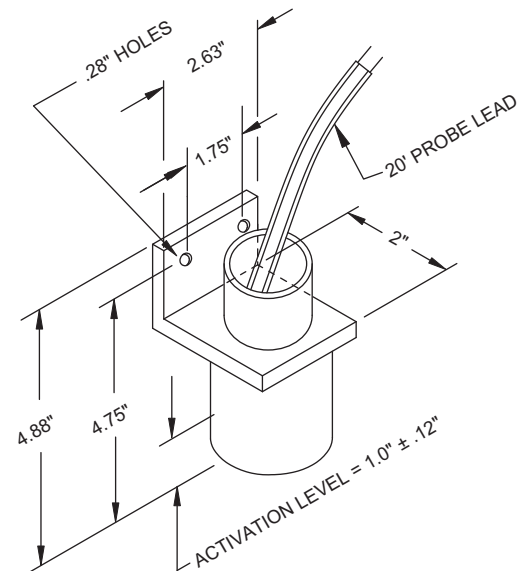

The information contained in this document is subject to change without notice. PermAlert Environmental Specialty Products believes the information contained herein to be reliable, but makes no representations as to accuracy or completeness.

PermAlert ESP offers a sole and exclusive one year warranty from date of shipment as is stated in the Standard Terms and Conditions of Sale for these products. In no event will PermAlert ESP be liable for any indirect, incidental, or consequential damages.

PermAlert ESP • 7720 North Lehigh Avenue • Niles, IL 60714  
(847) 966-2190, Fax (847) 470-1204, www.permapipe.com